

REVISION HISTORY			
REV.	DESCRIPTION	DATE	DRAWN BY
1	ORIGINAL PRINT	6/9/2022	T. JORGENSEN

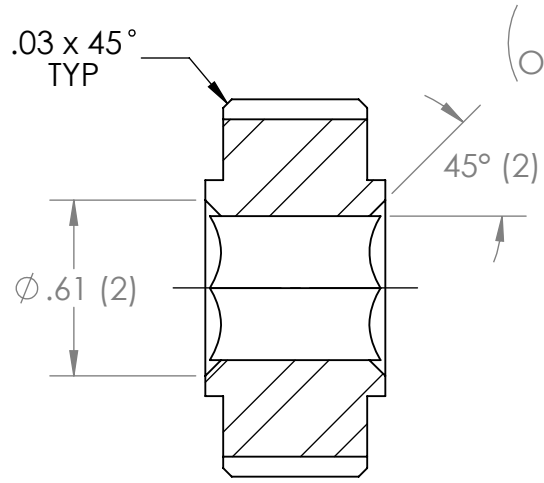

SECTION A-A

40T 32DP 20° P.A.
SPUR GEARSTOCK
CLEAN CUT
NO BURRS BETWEEN TEETH

Ø 1.31
(OUTSIDE DIAMETER)

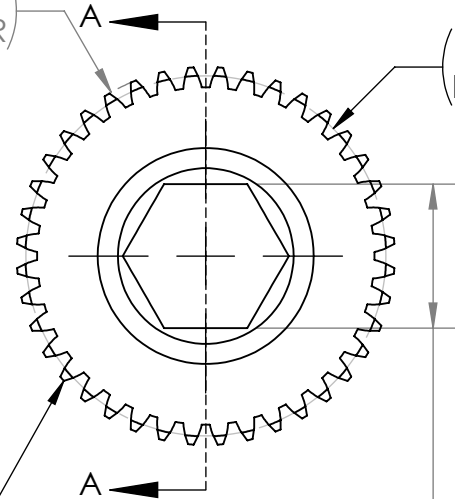

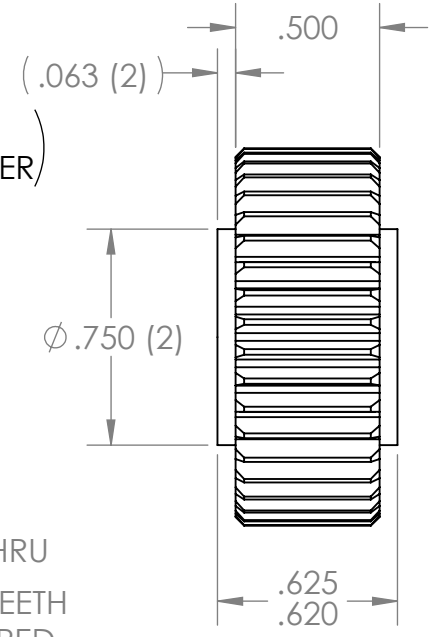

Ø 1.250
(PITCH DIAMETER)

.506
.501 HEX THRU
TIMING TO TEETH
NOT REQUIRED

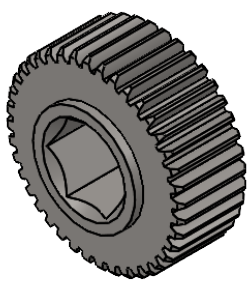

*** SEE CAD FOR ADDITIONAL TOOLPATH INFO***



UNLESS OTHERWISE SPECIFIED:		COMMENTS:																
DIMENSIONS ARE IN INCHES		DUAL DIMENSIONS ARE IN MILLIMETERS.																
TOLERANCES:		BREAK ALL SHARP EDGES.		TITLE:														
FRACTIONAL	±1/16	<table border="1"> <tr> <td>CHECKED</td> <td>NAME</td> <td>DATE</td> </tr> <tr> <td>ENG APPR.</td> <td>NM</td> <td>6/14/22</td> </tr> <tr> <td>MFG APPR.</td> <td></td> <td></td> </tr> <tr> <td>Q.A.</td> <td></td> <td></td> </tr> </table>		CHECKED	NAME	DATE	ENG APPR.	NM	6/14/22	MFG APPR.			Q.A.			SIZE	DWG. NO.	REV
CHECKED	NAME			DATE														
ENG APPR.	NM			6/14/22														
MFG APPR.																		
Q.A.																		
ANGULAR: MACH	±1°	A	am-4332	1														
ANGULAR: BEND	±5°	SCALE: 1.5:1																
ONE PLACE DECIMAL	±0.1	SHEET 1 OF 1																
TWO PLACE DECIMAL	±0.01																	
THREE PLACE DECIMAL	±0.005																	
FOUR PLACE DECIMAL	±0.0005																	
MATERIAL	4140 STEEL																	
FINISH	DEBURRED ZINC PLATED																	
DO NOT SCALE DRAWING																		

40T 32DP 20PA
500IN HEX BORE GEAR

SIZE **A** DWG. NO. am-4332 REV 1

SCALE: 1.5:1 SHEET 1 OF 1